

R18

Code No: 153AC

JAWAHARLAL NEHRU TECHNOLOGICAL UNIVERSITY HYDERABAD

B. Tech II Year I Semester Examinations, February - 2024

ANALOG ELECTRONICS

(Electrical and Electronics Engineering)

Time: 3 Hours

Max. Marks: 75

Note: i) Question paper consists of Part A, Part B.

ii) Part A is compulsory, which carries 25 marks. In Part A, answer all questions.

iii) In Part B, Answer any one question from each unit. Each question carries 10 marks and may have a, b as sub questions.

PART – A

(25 Marks)

1.a) Calculate I_D, V_R (Figure 1).

[2]

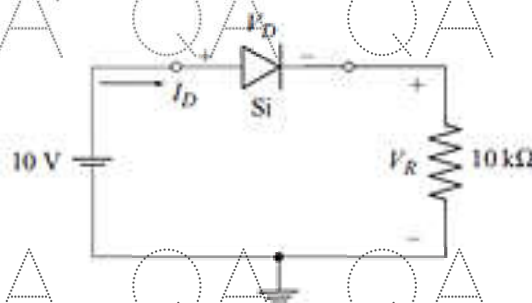

Figure 1

- b) Draw the output characteristic of BJT for common base configuration. [3]
- c) Sketch the transfer characteristic of an n-channel enhancement type MOSFET. [2]
- d) Derive output impedance and voltage gain of D-MOSFET. [3]
- e) Calculate the effective resistance seen looking into the primary of a 15:1 transformer connected to an 8Ω load. [2]
- f) What is the difference between a voltage amplifier and power amplifier? [3]
- g) What are the advantages of negative feedback amplifier? [2]
- h) Draw the circuit diagram of a Wien bridge oscillator. [3]
- i) Draw op-amp circuit as a summer. [2]
- j) Design an operational amplifier circuit with a gain of -20. Assume input resistance is equal to $5k\Omega$. [3]

9.a) Draw and explain BJT transistor RC phase shift oscillator. Find out the frequency of oscillations.

b) In an RC-phase shift oscillator $R = 1\text{k}\Omega$, collector resistance $R_c = 1\text{k}\Omega$ and $C = 0.1\mu\text{F}$. Calculate the frequency of oscillations. [7+3]

10.a) The common-mode rejection ratio CMRR of an operational amplifier is about 120 dB and difference-mode voltage gain is 10,000. Determine common-mode gain.

b) An operational amplifier has slew rate about $0.45\text{V}/\mu\text{s}$ and used as an inverting amplifier with a gain 100. The voltage gain vs frequency curve of an operational amplifier up to 20 kHz is flat. What is the maximum peak to peak input signal that can be applied to the operational amplifier without distorting the output voltage? [4+6]

OR

11.a) Draw inverting amplifier and derive its gain expression.

b) Determine output voltage V_0 and current flows through R_1, R_2, R_3, R_f . Assume $V_1 = 2\text{V}$, $V_2 = -2$, and $V_3 = 3\text{V}$ (figure 7). [5+5]

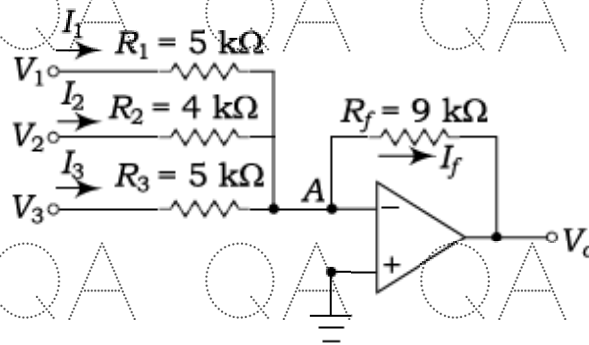

Figure 7

---ooOoo---